

BATTERY RAIL VEHICLES

Ben Johnston

BE (Hons) GradIEAust MIET

President, Hobart Northern Suburbs Rail Action Group Inc.

University of Tasmania

SUMMARY

This paper discusses the application of modern commercially available traction batteries to electric rail traction. For rail systems with few vehicles and a route that facilitates frequent/opportunistic charging, on board batteries could yield reduced capital and life-cycle costs compared with conventional rail electrification. Passenger rail vehicles powered by lead acid batteries have been used in the past; however the heavy maintenance associated with conventional lead acid batteries, recharging limitations, and the absence of power electronics made these vehicles impractical. Modern traction batteries have much improved performance characteristics such as rapid recharge, long cycle life, and are maintenance free.

The feasibility of using a modern battery electric rail vehicle is investigated by simulating a railcar running on the existing non-electrified rail line in Hobart, Tasmania. A modern commercial valve regulated lead acid (VRLA) battery is selected and the optimum economic configuration and charging regime designed. The life cycle cost of the battery solution compares favourably with conventional overhead electrification following a desktop study summarised in this paper.

INTRODUCTION

As traditional fossil fuels become increasingly scarce, and the human population continues to grow, there are greater economic and environmental incentives for society to seek out alternative energy sources and utilise energy in a more efficient manner. This paper touches on the second of these objectives by proposing a model of energy efficient battery rail transportation. The model is developed as a case study for the Australian city of Hobart, Tasmania, and considers the life cycle cost of battery storage versus the installation of overhead line equipment for an existing rail alignment between Hobart CBD and the outer suburb of Bridgewater.

In Australia, the transport sector currently accounts for approximately 25 per cent [1] of primary energy use. Road and air transport make up the bulk of this energy consumption, with 70 per cent of transportation energy being derived from a liquefied fuel source. Rail transport constitutes a meagre 2 per cent [1] of the total sector energy consumption; a reflection of its relatively high energy efficiency and perhaps, a low market share.

Rail vehicles are the most efficient form of passenger transport. Take Melbourne for example, a large Australian city where all familiar modes of land based passenger transport are represented. This includes predominantly petroleum fuelled cars, diesel buses, electric trams, and electric/diesel trains. The relatively high energy efficiency of rail transportation is highlighted in Figure 1, which depicts the energy consumption

rate per passenger kilometre of these various modes of transport for the average weekday in Melbourne.

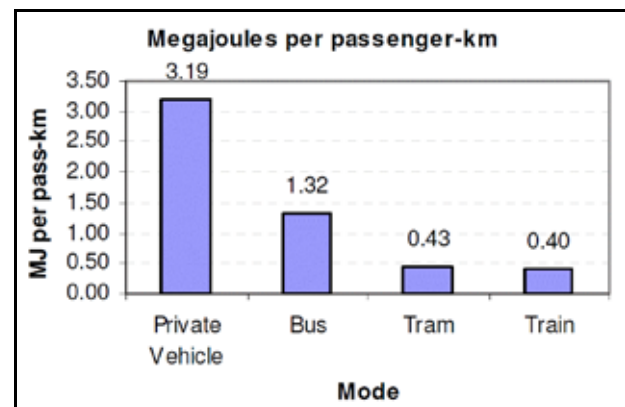

Figure 1 : Average megajoules per passenger kilometre by mode, Melbourne 2006 [2]

While being extremely efficient, the drawback of electric rail transport is the expense and complexity of installing the overhead supply equipment; which can only be justified for extensively utilised routes. For smaller systems, with a running regime that facilitates frequent/opportunistic charging, vehicle mounted batteries could afford the advantages of electric traction with lower capital and life cycle costs than conventional rail electrification. The use of vehicle mounted batteries forms the basis of the Hobart to Bridgewater case study developed in this paper.

NOTATION

| | |
|------|---------------------------|
| DOD | Depth of discharge |
| HES | Hybrid energy storage |
| LRV | Light rail vehicle |
| NiMH | Nickel-metal hydride |
| OLE | Overhead line equipment |
| VRLA | Valve regulated lead acid |

1 ELECTRIC TRACTION

The first application of electricity to practical traction purposes dates back to the now famous Siemens locomotive first exhibited at the Berlin Industrial Exhibition in 1879. [3]



Figure 2 : Siemens locomotive, Berlin 1879 [3]

Electric traction is a well established form of motive power for rail transport. Electric power can be produced from renewable resources, making it an environmentally friendly option. Despite the relatively high levels of efficiency and low operating costs, the initial infrastructure costs associated with overhead line equipment (OLE) for electric railways is large and can be a deterrent.

1.1 Battery Rail Traction: A Brief History

The first battery rail car was used on the Royal Bavarian State Railway in 1887. Between 1900 and 1960 a further 398 battery railcars were built and put into service by the German Federal Railways. The last unit was withdrawn in 1990.

In 1926 New Zealand Railways purchased an experimental Edison Storage Battery Railcar. Though successful and popular with passengers it lasted a mere eight years, being destroyed in a depot fire in Christchurch in 1934. [4]

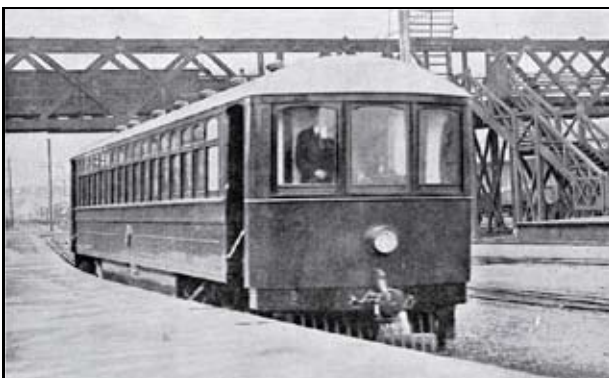

Figure 3 : Edison Storage Battery Railcar departing Christchurch for Lyttelton [4]

In 1958 British Rail and the North of Scotland Hydro-Electric Board collaborated to convert several diesel railcars to battery propulsion but the technology was not pursued. [5]

The railways reported favourable experience with operation and servicing, due to simple drive equipment, easy maintenance, few breakdowns, and low wear. The limitations of battery storage were the inability to run all day on a single charge, long re-charge times and frequent battery maintenance (flooded lead acid cells).

More recent applications have adopted better batteries, frequent recharging, and better utilisation of regenerative braking. A renewed interest or “renaissance” in battery rail has been spawned by the desire to remove overhead wiring and masts, mainly for reasons of aesthetics and public safety. For example, in 2007 ALSTOM commissioned their Citadis light rail vehicles (LRV) fitted with roof mounted NiMH batteries in the French city of Nice. The trams travel wireless sections of up to 1 km on battery power (*Figure 4*). When the trams return to the overhead the batteries recharge and the trams continue on overhead supply. [6]



Figure 4 : ALSTOM LRV, Nice, France, 2007 [7]

Other companies have been experimenting with on-board battery storage. In 2008 Siemens completed a successful trial of their Sistras Hybrid Energy Storage (HES) system combining a NiMH battery and double-layer capacitor. Sistras HES can complete its charging cycle in just 20 s, taking power from the overhead or a charging point. This provides sufficient power to run the LRV up to 2.5 km. [6] Kawasaki has also been testing its SWIMO wireless LRV in Sapporo, Japan. SWIMO again uses NiMH batteries, can be fully charged in three to five minutes for a range of 10 km. During testing a range of 37.5km was achieved with a full discharge (100% DOD) of the battery. [6]

1.2 Advantages of Battery Electric Vehicles

On board battery energy storage offers many benefits over conventional rail electrification. From a technical perspective, there are no issues of noise or wear from a moving contact against electrified conductors. Track/signalling circuits are not complicated by having to accommodate traction return circuits and the absence of long traction circuits would reduce the interference to communication systems or corrosion problems due to electrolysis. Furthermore, the efficient utilisation of regenerative braking energy is assured since a battery vehicle does not have to rely on another vehicle to be motoring in the same electrical section to utilise this energy.

From a safety perspective, a battery electric vehicle removes much of the potential for the public or personnel to come into contact with live electrified equipment. Battery electric vehicles are unlikely to be left stranded as there are no gaps required for isolation of electrical sections and junctions. Faults caused by vehicles do not affect other vehicles in the same electrical section. In the event of a power supply failure, a vehicle would simply remain at the charging station, which is more convenient than a conventional electric train which could be stranded in a problematic location.

2 CASE STUDY: HOBART - BRIDGEWATER

Hobart, the capital of the Australian state of Tasmania, had passenger rail servicing its northern suburbs between 1875 and 1978. Today a single non-electrified 1067 mm gauge track remains for limited freight services. Tasmanian electricity is predominantly generated from hydro and wind renewable sources, which represent 87% of the local installed grid capacity [8]. The existing rail track and renewable energy sources make the northern suburbs of Hobart an excellent candidate for electric rail traction.

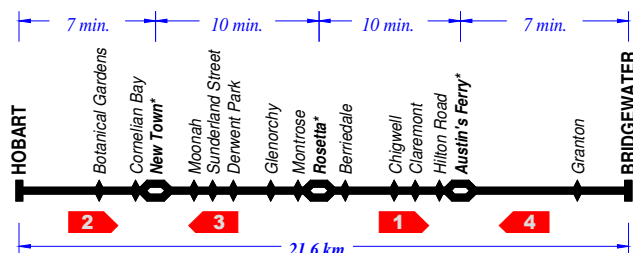

Figure 5 : Hobart – Bridgewater comprising three intermediate passing loops/stations forming four sections for up to four vehicles

In the proposed model, rail vehicles would stop when required at seventeen stations similar to the former Hobart suburban rail system. In peak periods, four vehicles would be dispatched crossing at three intermediate stations. Based on running times of the former system and allowing for crossing delays the Hobart-Bridgewater section could be traversed in around 34 min. A 6 min turnaround at each terminus (during which time battery

charging could take place and the driver could change driving positions), gives a departure interval of 20 min in each direction (*Table 1*)

Table 1 : Example morning peak timetable

| Up Station | Train 1 | Train 2 | Train 3 | Train 4 |
|------------------|---------|---------|---------|---------|
| Bridgewater | 7:00 | 7:20 | 7:40 | 8:00 |
| Austin's Ferry* | 7:07 | 7:27 | 7:47 | 8:07 |
| Rosetta* | 7:17 | 7:37 | 7:57 | 8:17 |
| Glenorchy | 7:20 | 7:40 | 8:00 | 8:20 |
| Newtown* | 7:27 | 7:47 | 8:07 | 8:27 |
| arr. Hobart | 7:34 | 7:54 | 8:14 | 8:34 |
| Down Station | Train 1 | Train 2 | Train 3 | Train 4 |
| Hobart | 7:40 | 8:00 | 8:20 | 8:40 |
| Newtown* | 7:47 | 8:07 | 8:27 | 8:47 |
| Glenorchy | 7:54 | 8:14 | 8:34 | 8:54 |
| Rosetta* | 7:57 | 8:17 | 8:37 | 8:57 |
| Austin's Ferry* | 8:07 | 8:27 | 8:47 | 9:07 |
| arr. Bridgewater | 8:14 | 8:34 | 8:54 | 9:14 |

*crossing stations

2.1 Battery Design and Analysis

The total energy supplied to an electric train is expended in five modes:

- i) Accelerating the train in a horizontal direction;
- ii) Accelerating the revolving parts;
- iii) Doing work against gravity, if the train is ascending a gradient;
- iv) Doing work against the resistances to motion;
- (v) Supplying auxiliary equipment and losses in traction equipment.

Conversely, energy may be recovered during the first three modes. This is known as regenerative braking.

The energy consumed by the proposed vehicle running the proposed stopping/charging regime is calculated by applying formulae for train resistance [3, 9, 10] to track geometry. The most onerous energy demand is simulated by incorporating conservative estimates of efficiency stopping (and starting) at all stations.

A battery consists of a number of electro-chemical cells. Each cell consists of a positive and negative electrode, a separator and electrolyte. The positive electrode is called the anode and the negative electrode, the cathode. The anode receives electrons from the external circuit when the cell is discharged and the cathode donates electrons to the external circuit as the cell is discharged. Depending on the type of cell, the electrolyte is there to provide a mechanism for current to flow between the anode and cathode, and can also play a part in the chemical reaction.

Battery characteristics such as capacity, cycle life, and efficiency are all inter-related and influenced by demand parameters including cycle depth or

conversely depth of discharge (DOD), discharge rate, and the operating temperature.

VRLA and NiMH are the cell types readily available for traction purposes. Both cells have similar life cycle characteristics against DOD. The NiMH battery has around double the energy density of the VRLA, but at least ten times the cost of the equivalent capacity VRLA. [11]



Figure 6 : Energys Genesis VRLA battery G70EP: 331x168x176 mm 24.3 kg [12]

A Genesis G70EP VRLA battery is not the highest energy density storage option available but it was selected for modelling as cost and detailed performance characteristics are available. Relevant characteristics are summarised in Table 2 and Figure 7.

The cycle life of a battery is defined as the number of cycles a battery delivers before its capacity falls below the acceptable level, usually defined as 80% of rated capacity. Figure 7 illustrates the rapid reduction in cycle life as the DOD is increased. For example deep cycling (80% DOD) can be achieved 400 times. Field testing involving shallow cycling (2-3% DOD) revealed a cycle life in excess of 150,000 cycles.

Table 2 : Genesis (G70EP) Performance Data, constant discharge to 1.67 Vpc at 25°C [12]

| Run time | Amps | Watts | Capacity (Ah) | Energy (Wh) |
|----------|-------|-------|---------------|-------------|
| 5 min | 342.4 | 3680 | 29 | 307 |
| 10 min | 228.5 | 2519 | 38 | 420 |
| 15 min | 173.4 | 1940 | 43 | 485 |
| 30 min | 102.5 | 1173 | 51 | 587 |
| 60 min | 57.4 | 670 | 57 | 670 |
| 90 min | 40.6 | 486 | 61 | 729 |
| 5 hr | 13.4 | 161 | 67 | 805 |
| 8 hr | 8.7 | 105 | 70 | 840 |
| 10 hr | 7.1 | 86 | 71 | 860 |
| 20 hr | 3.9 | 47 | 78 | 940 |

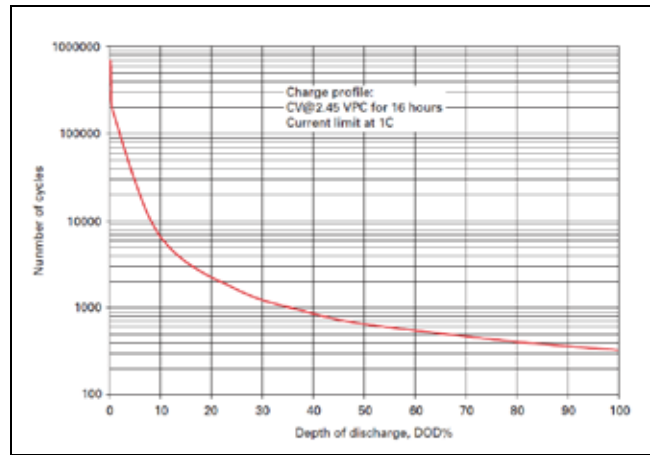

Figure 7 : Genesis cycle life against DOD [12]

Calculating the number of batteries required for a particular DOD is not straight forward since the total energy consumed by the vehicle changes as its mass changes with the number of battery modules installed and the capacity of each battery module changes with the effective run time which depends on the journey time and DOD. Therefore an initial estimate for energy consumption for a desired DOD is required and an iterative process performed to refine the number of battery modules required, thus influencing the vehicle mass.

It should also be noted that the float or shelf life of the G70EP is between 10 years (25°C) and 15 years (20°C) [12]. Based on this information there is little merit in a designing a cyclic charging regime to deliver a cycle life exceeding 10 years.

2.2 Energy Simulation and Charging Scenario Optimisation

A simple simulation was performed which calculated the energy consumed as the theoretical rail vehicle progresses from Hobart to Bridgewater. The following parameters were used in the simulation with mass confirmed following optimisation iterations.

- Vehicle mass: 49.5 tonne
- Traction power: 500 kW
- Maximum speed: 20m/s
- Motoring efficiency: 85%
- Regenerating efficiency: 80%
- Battery efficiency: 85%*

* Genesis VRLA batteries typically operate between 77 and 97% efficiency depending on the current per cell, charge returned, and operating temperature.

Table 3 : Energy consumption between charging stations (49.5 tonne vehicle)

| Charging Interval from | to | Consumption {kWh} |
|------------------------|----------------|-------------------|
| Hobart | New Town | 14.04 |
| New Town | Rosetta | 14.89 |
| Rosetta | Austin's Ferry | 11.60 |
| Austin's Ferry | Bridgewater | 4.70 |
| <i>sum:</i> | | 45.24 |

A number of charging scenarios were evaluated including one recharge per day and recharging at each terminus. Both these regimes yielded high annualised battery costs of at least \$160k per vehicle.

A better option was more frequent (opportunistic) charging by recharging at each terminus and the three intermediate passing/charging stations. The energy simulation results for the most onerous scenario (stopping all stations) are displayed in *Figure 9* and *Figure 10*. Battery sizing methodology is summarised below:

Specify DOD = 3%
 G70EP Cycle life = 150,000 cycles [*Figure 7*]
 Effective discharge time = transit time / DOD
 = 10 min / 3%
 = 5.6 hr
 G70EP energy = 814 Wh/module [*Table 2*]
 Maximum recharge = 14.89 kWh [*Table 3*]
 Modules required {most onerous}
 = maximum recharge / (DOD x G70EP energy)
 = 14.89 kWh / 3% 814 Wh/module
 = 610 modules
 Battery mass = 610 x 24.3 kg
 = 14.8 tonne

2.3 Battery Recharging

The required recharge time is a function of the energy required and the “charging” power. For example, the time to fully recharge the most onerous energy expended between New Town to Rosetta is:

Time = (Max recharge/Battery effic.) / Power
 = 14.89 kWh / 85% / 500 kW
 = 2 min.

It follows that doubling the charging power could halve the charging time. Also, longer charging durations at each end of the route and shallow charging regime also add flexibility in that 100% recharging at all stations is not necessary.

2.4 Battery Costing

The cycle life and number of modules required is affected by the charging/running regime, and thus determines the life cycle cost of the battery system. Therefore the years between battery replacement and annual cost is calculated as follows:

= Cycle life / proposed cycles per year
 = 150,000 cycles / 15,600 cycles/year
 = 9.6 years

Retail price for each Genesis G70EP module
 = US\$261
 = AU\$313 (dated 10/6/2010)

Battery cost per vehicle
 = 610 x AU\$313
 = AU\$190,930

Annual battery cost per vehicle
 = Batt. cost per vehicle / yrs betw. replacement
 = AU\$190,930 / 9.6 years
 = AU\$19.9k/year

For five vehicles (four + one spare)
 = 5 x AU\$19.9k/year
 = AU\$99.3k/year for battery fleet

Plus, the annual cost of charging installations,
 (11 kVAC / 750 VDC 1,000 kVA chargers)
 = 5 x AU \$500k / 50 year life
 = AU\$50k/year for charging facilities

**Total annual cost of batteries plus chargers
 = AU\$149k/year**

2.5 Cost of Overhead Electrification

The capital costs (design and construction) of electrifying an existing route range from £550k to £650k per single track kilometre. [13]

AU\$1.0M per single track km on 10/6/2010

Therefore to Electrify 21.6 km of single track railway from Hobart to Bridgewater is approx. AU\$21.6M

Ignoring maintenance costs and the time value of money, the annual cost apportioned over a 50 year asset life is: **AU\$432k per year**

3 CONCLUDING REMARKS

A quick and simple comparison of a traditional overhead electrification scheme and an on-board battery scheme tends to favour the latter option for a specific running regime and a small (five) number of rail vehicles. The most onerous running regime (stopping all stations) and conservative efficiencies have been applied to derive this result. The use of VRLA battery technology is deemed a medium density storage option and higher density options are available at a differing cost (see Appendix A)

It has been shown that battery electric railcars could provide the northern suburbs of Hobart with a relatively cheap, innovative, and efficient transport system which compliments Tasmania’s existing “clean and green” image. Much of the required infrastructure is already in place, the main elements outstanding being the vehicles themselves and the charging infrastructure.

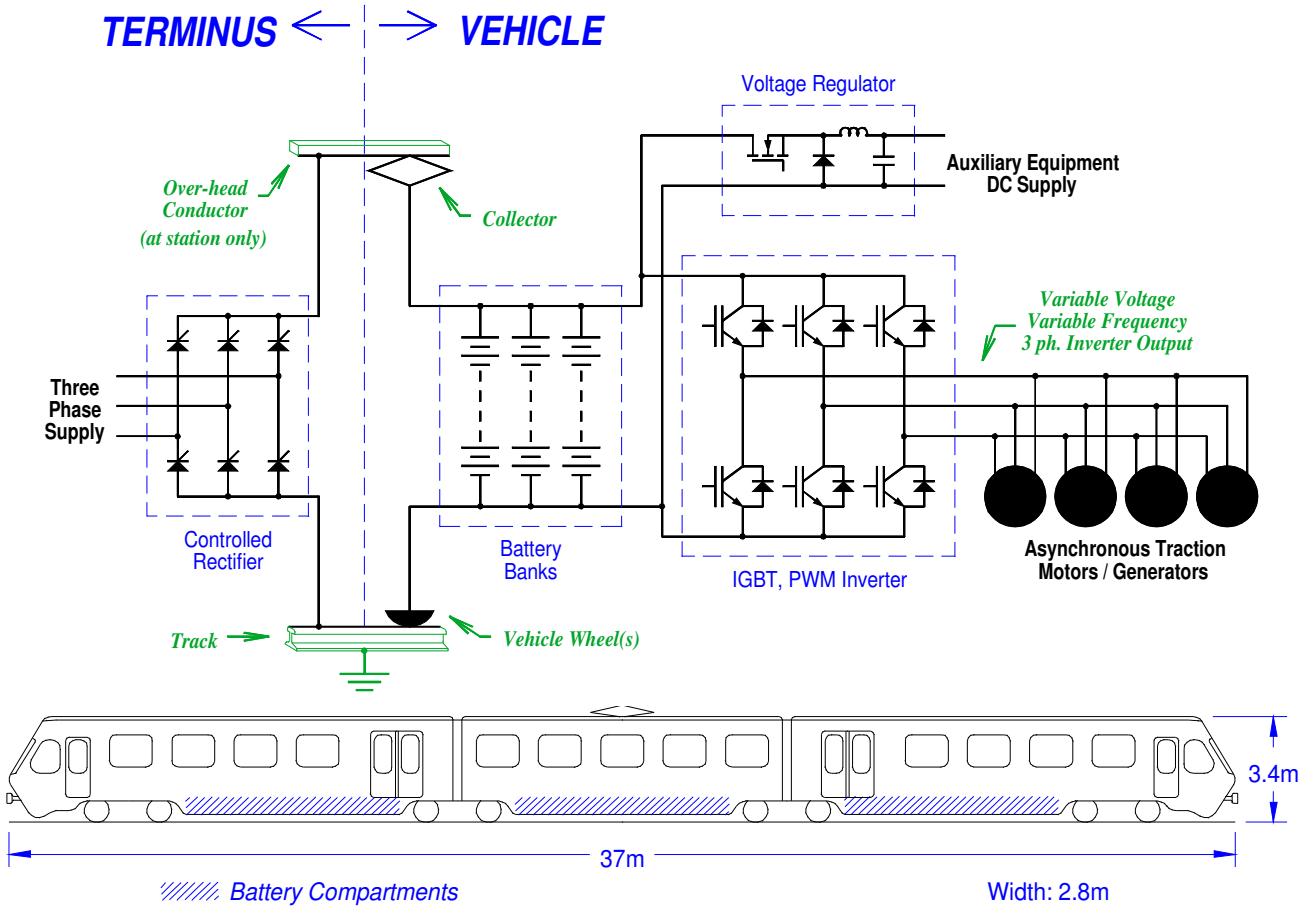

| | |
|-----------------------|---|
| Battery: | 610 Genesis G70EP 12V, 70Ah valve-regulated lead acid (VRLA) battery modules |
| Battery mass: | 14.8 tonne (610 x 24.3kg) |
| Battery storage area: | 34 m ² (610 x 0.33071m x 0.16815m) |
| Battery capacity: | 497 kWh(@ applicable 5 hr. discharge rate) |
| Battery life: | 9.6+ years |
| Battery charging: | Constant DC voltage charging at 5 locations between and including Hobart and Bridgewater. Average 500kW for up to 2 minutes duration – soft/ramped start/stop |
| Service mass: | 49.5 tonne ~ 'light rail' |
| Traction: | 4 x 125kW, 3ph. asynchronous motors. |
| Auxiliary load: | 1kW (average/constant) assuming that heating/cooling systems would be active at re-charge stations and not use batteries. |
| Acceleration: | 1.0 m/s ² (acceleration and regenerative deceleration on level track) |
| Passenger capacity: | Approx 100 seated passengers |

Figure 8 : Concept design of proposed battery rail vehicle

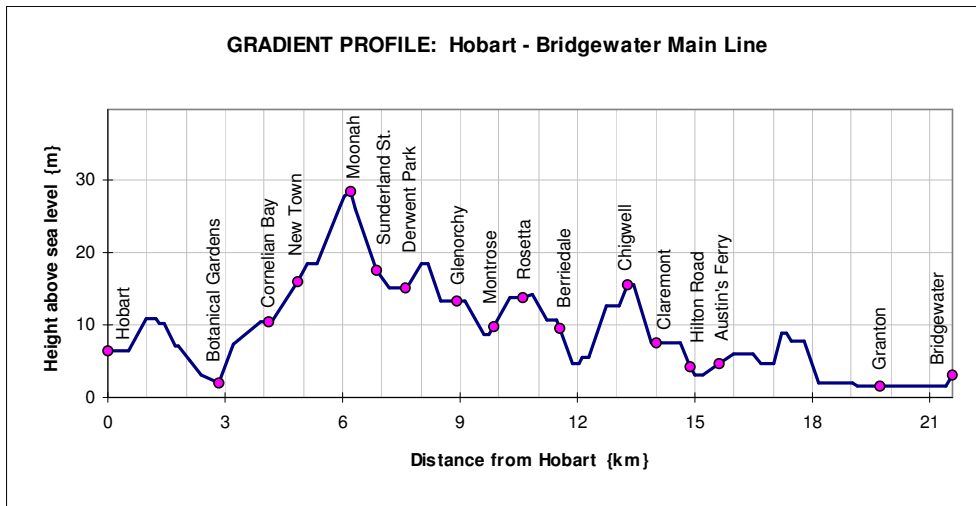

Figure 9 : Hobart to Bridgewater gradient profile showing 1974 stations [TGR]

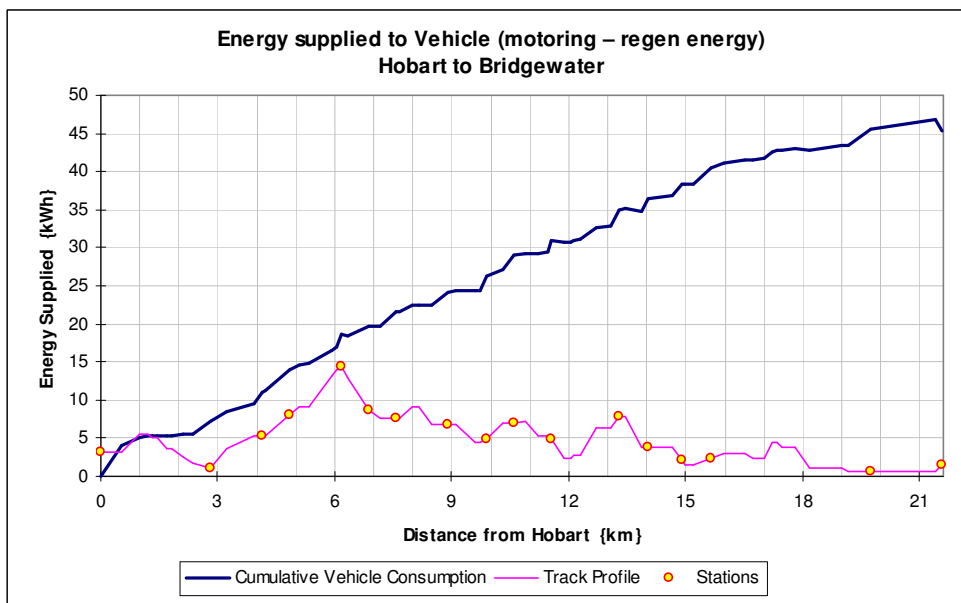

Figure 10 : Energy simulation from Hobart to Bridgewater, stopping all stations

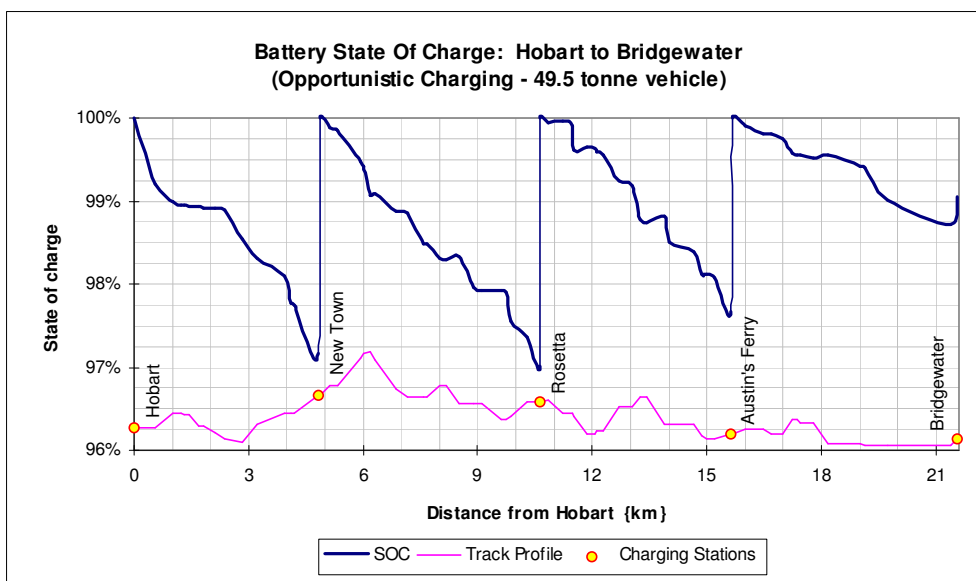

Figure 11 : Battery State of Charge for 49.5 tonne rail vehicle with 610 G70EP modules

4 REFERENCES

- [1] Australian Bureau of Agricultural and Resource Economics (ABARE) Energy in Australia 2004
- [2] Alford G and Whiteman J A spatial analysis of future macro-urban form, greenhouse gas emissions and transport energy outcomes for Melbourne (2008)
- [3] Dawson P Electric Traction on Railways (1909)
- [4] The New Zealand Railways Magazine volume 2 issue 10 (February 1928)
- [5] The Railway Magazine (June 1958)
- [6] International Railway Journal volume 49 issue 6 (June 2009)
- [7] Hall G (2007)
- [8] Department of Infrastructure, Energy & Resources (DIER)
http://www.dier.tas.gov.au/energy/renewable_energy
- [9] Dover AT Electric traction 3rd edition (1960)
- [10] Jenkinson SH Train resistance on the 3ft. 6in. gauge (1924)
- [11] Rail Safety and Standards Board (RSSB) T779: Energy storage systems for railway applications (2009)
- [12] EnerSys Genesis application manual 7th edition (November 2008)
- [13] Rail Safety and Standards Board (RSSB) T633: Study on further electrification of Britain's railway network (2007)

5 APPENDIX: ENERGY STORAGE OPTIONS

Energy may be stored in either its kinetic form (eg. flywheels) or potential form (eg. batteries). For electric vehicles the gravimetric and volumetric energy density is important and listed for various technologies in *Table 4*. Where a combination of technologies or fuels is applied the vehicle is referred to as a hybrid.

Table 4 : Energy density of various energy storage technologies [4]

| Type of Storage | Wh/kg | Wh/L |
|---|--------|-------|
| Petroleum | 11,660 | 8,750 |
| Hydrogen carbon tanks 5,000 psi | 2,000 | 700 |
| Hydrogen carbon tanks 10,000 psi | 1,666 | 1,165 |
| Conventional Flywheel | 3 | 2 |
| Modern (experimental) flywheel | 25 | 34 |
| Compressed air carbon tanks Isothermal 4500 psi | 137 | 48 |
| Hydraulics | 2 | 2 |
| Super capacitor | 5 | 6.5 |
| Lead acid battery* | 30 | 70 |
| Advanced lead acid (VRLA) battery* | 40 | 96 |
| Nickel Metal Hydride (NiMH) battery* | 70 | 180 |
| Lithium Ion battery* | 120 | 250 |

* Battery energy at C/3 rate (3 hour discharge)

Petroleum is an obvious choice to fuel a vehicle due to its very high energy density and relative ease of storage and transport. However, petroleum is a finite and diminishing resource with formidable environmental and social consequences associated with its extraction and use. Alternative forms of energy storage are outlined below.

5.1 Fuel Cells

A fuel cell converts chemical energy to electrical energy by electrochemical reactions. Fuel is continuously supplied to one electrode and an oxidant (usually oxygen) to the other electrode.

The constraints with Hydrogen fuel cells include cost, fuel containment, and efficiency. In practical cells, conversion efficiencies of up to 80% have been attained, however hydrogen produced from water via electrolysis is at best 60% efficient [5]. Hydrogen fuel cells have been successfully used in experimental road vehicles owing to the very high energy density, but are yet to see widespread use.

5.2 Flywheels

Flywheels have been used to store and stabilise energy for hundreds of years. Recent advances in bearing technology, power electronics, vacuum enclosures, and modern materials have substantially improved their performance characteristics.

The energy stored in a flywheel is proportional to the square of its speed and recent applications in F1 racing cars have used speeds up to 60,000 rpm. A good example of flywheel application to rail transport is the Parry People Movers (*Figure 12*) where 0.5 ton 2500 rpm flywheels power small rail vehicles which are re-charged at regular station stops. [11]



Figure 12 : PPM 60, Parry People Movers Ltd UK

There remain technical challenges to modern flywheel energy storage including safety, reliability, and the need for higher power.

5.3 Hydraulic/Pneumatic Systems

Modern hydraulic systems are capable of capturing braking energy and storing it in a hydraulic accumulator. The energy stored by the compressible medium (gas) is equal to the product of pressure and volume. The upper limit on storage efficiency is relatively low as much of the input energy to the compressible medium manifests itself as heat and is wasted. [11]

5.4 Super Capacitors

Super (double layer) capacitors are commercially available and manufactured in cells having capacitance of up to 5,000 farads at voltages between 2.5 and 3.0 V. The energy stored is proportional to capacitance and the square of the voltage.

Advantages of Super capacitors include high power density, very high rates of charge and discharge, and very high cycle life. Disadvantages include the high self-discharge and high cost, when compared to a battery. [11]